

Propagation Channel Emulator

ECP-70



1 PRODUCT DESCRIPTION

The ECP (**Propagation Channel Emulator 70**) synthesizes the principal phenomena of propagation occurring on RF signal links between earth and space.

Developed by the R&D laboratory, the ECP demonstrates the know-how of ELTA in the field of high-speed data processing and integration: up to 3 synchronized channels can take place into a single generic SPACELINK Blackline serie. The new Blackline mainframe presents a large high definition and touch sensitive screen, including an intuitive user interface. GUI software and signal processing software are in situ upgradable via the remote interface.

ELTA distributes the CNES PROPALOG software to perform realistic simulations according to the most advanced statistical disturbance models.

2 THE ECP APPLIES A TRANSFER FUNCTION ON A 40MHZ CHANNEL

IT CAN SIMULATE THE FOLLOWING DISTURBANCES:

- VARIABLE DELAY UP TO 500 MS (continuous phase)
- TIME JITTER
- FREQUENCY DOPPLER SHIFT
- LEVEL FADING
- AWGN NOISE GENERATOR (option)
- AMPLIFIER NON LINEARITIES (option)
- MULTIPATH RICE/RAYLEIGH CHANNEL SIMULATOR (option)
- TRACKING ERROR SIGNAL SIMULATOR (option)
- PHASE NOISE GENERATOR (option)
- OUTPUT ANALOG FILTER (option)
- CW JAMMERS (option)
- PROPALOG DATA GENERATION SOFTWARE (option)

3 TYPICAL APPLICATIONS FOR THE ECP INCLUDE

- EARTH TERMINAL TESTING
- SATELLITE PAYLOAD TESTING
- SATELLITE SYSTEM INTEGRATION TEST BENCH
- WIDEBAND SPECTRUM CHECKING
- TRACKING SYSTEM TEST BENCH
- EARTH MOBILE COMMUNICATION TESTING



www.elta.fr

Propagation Channel Emulator

ECP-70

4 PROCESS DESCRIPTION

As shown in the block diagram, the if signal is down-converted by the 12-bit state-of-the-art high-speed ADC.

THE SEQUENCER IS IMPLEMENTED IN A POWERFUL FPGA PERFORMS:

- PASSBAND FILTERING,
- DATA EXCHANGE WITH THE MEMORY TO GENERATE THE DELAY,
- AWGN NOISE GENERATION (option),
- PHASE NOISE GENERATION (option),
- MULTI-PATH ECHOING,
- FREQUENCY SHIFT USING A NCO AND A COMPLEX MIXER,
- SIN X / X AND BANDWIDTH EQUALIZATION TO GUARANTEE A BETTER FLATNESS.

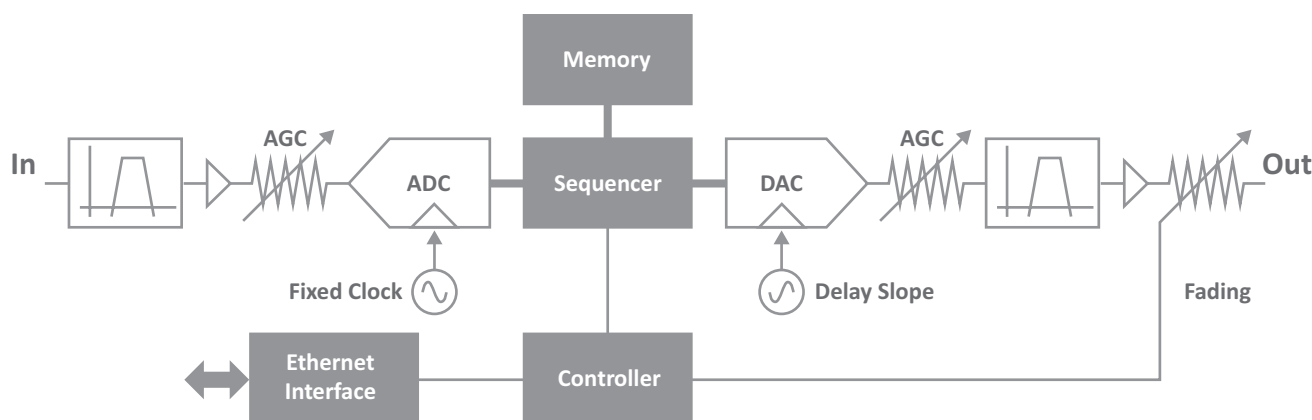

5 PROCESSING MODES

THE ECP PLAYS BACK SIMULATION SCENARIOS IN TWO DIFFERENT MODES:

- **STATIC MODE:** the transfer function is set up by asynchronous single remote commands.
 - **REAL-TIME MODE:** the transfer function is set up by means of 1 second playback buffer through the remote link.
- Data are applied at a 1, 10 or 100 Hz rate, through a 10 kHz linear interpolator. A logic TTL pulse signal is available to synchronize slave channels (up to 2 inside a single unit) to the master channel. This mode is especially useful to synchronize multi-channel link.



www.elta.fr

Propagation Channel Emulator

ECP-70

6 LOCAL MODE GRAPHICAL USER INTERFACE



START WINDOW

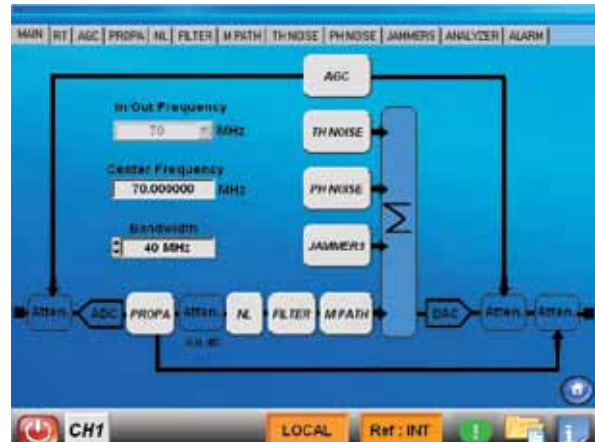

MAIN WINDOW

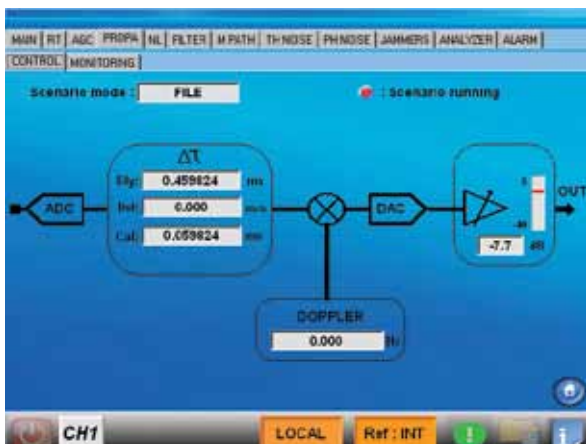

PROPAGATION WINDOW

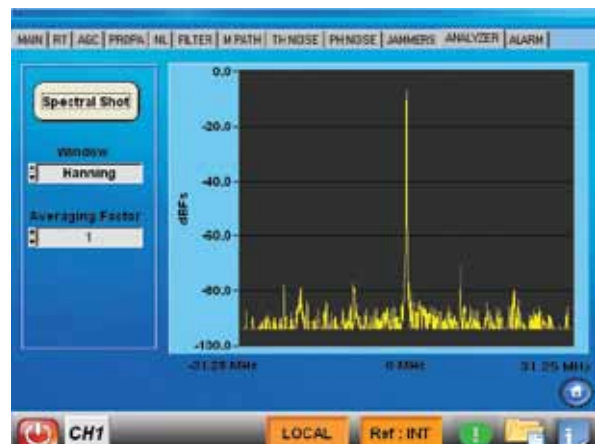

SPECTRUM ANALYSER WINDOW

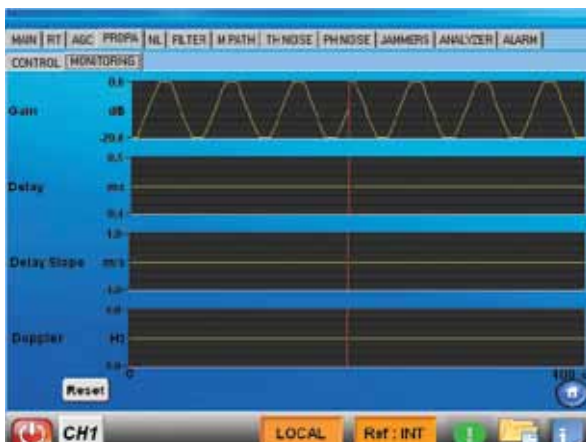

TRACE WINDOW

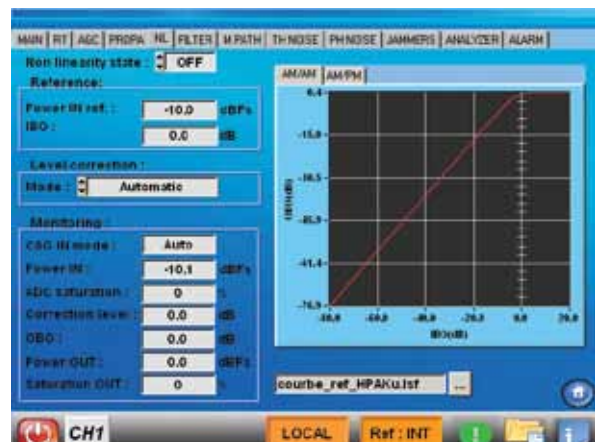

NON LINEARITIES WINDOW



Propagation Channel Emulator

ECP-70

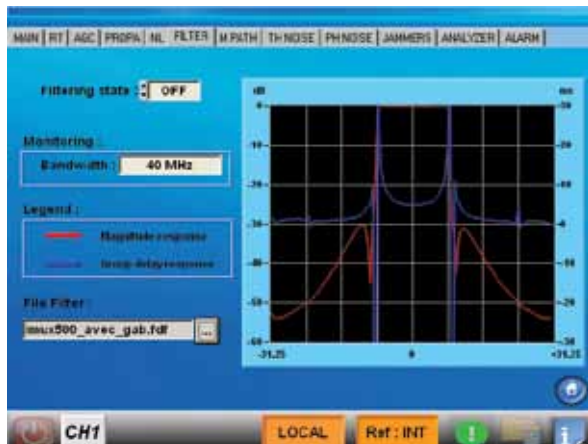

FILTER FUNCTION WINDOW



PHASE NOISE WINDOW

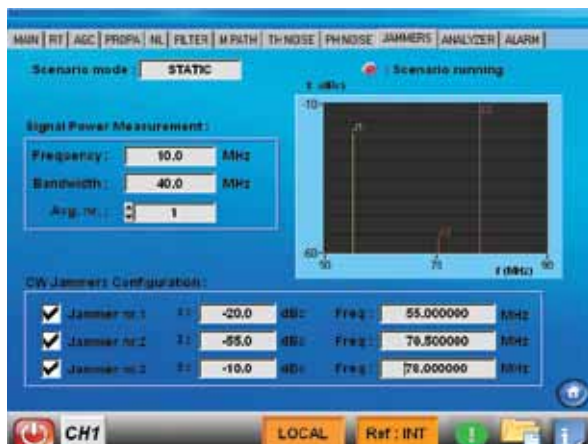

JAMMERS WINDOW



THERMAL NOISE WINDOW



MULTI PATH WINDOW

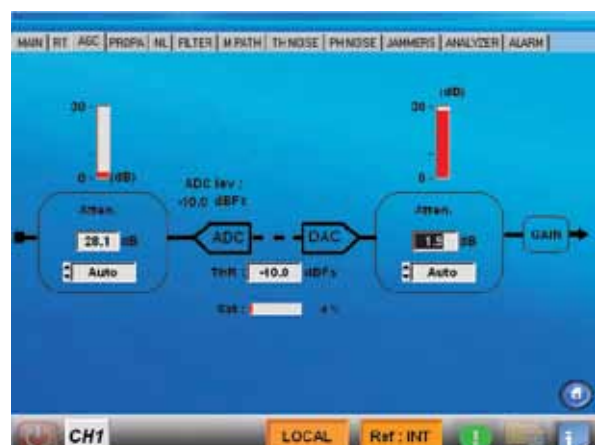

CGA WINDOW



Propagation Channel Emulator

ECP-70

7 SOME USEFUL CONFIGURATIONS

3 CHANNELS ECP SPACELINK FOR SCIENTIFIC SATELLITES TESTING

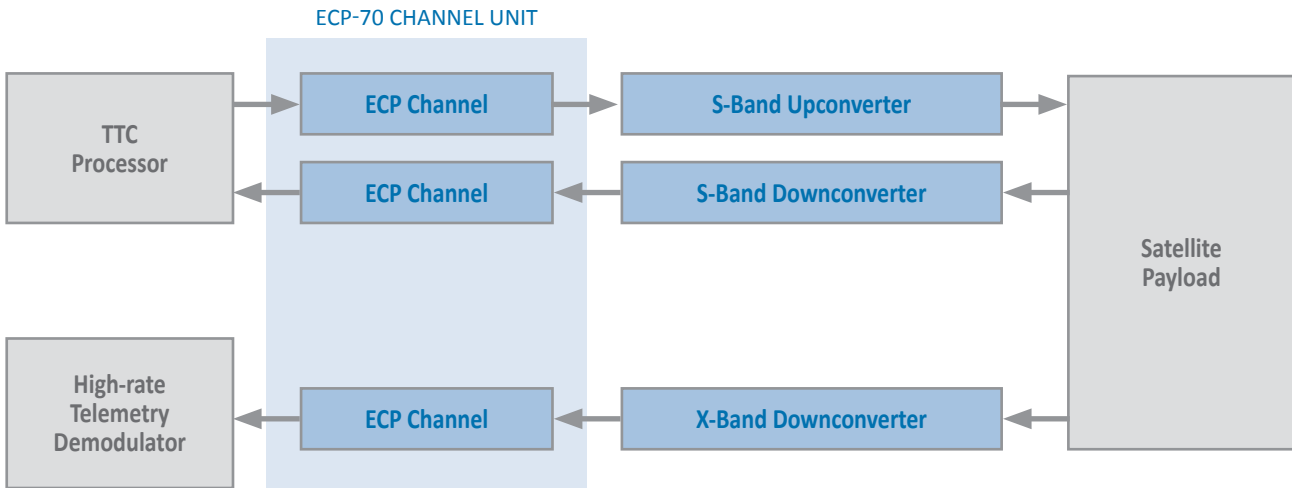

4 CHANNELS ECP SPACELINK FOR TELECOMMUNICATION SATELLITES TESTING

(this configuration requires 2 x ECP-70)

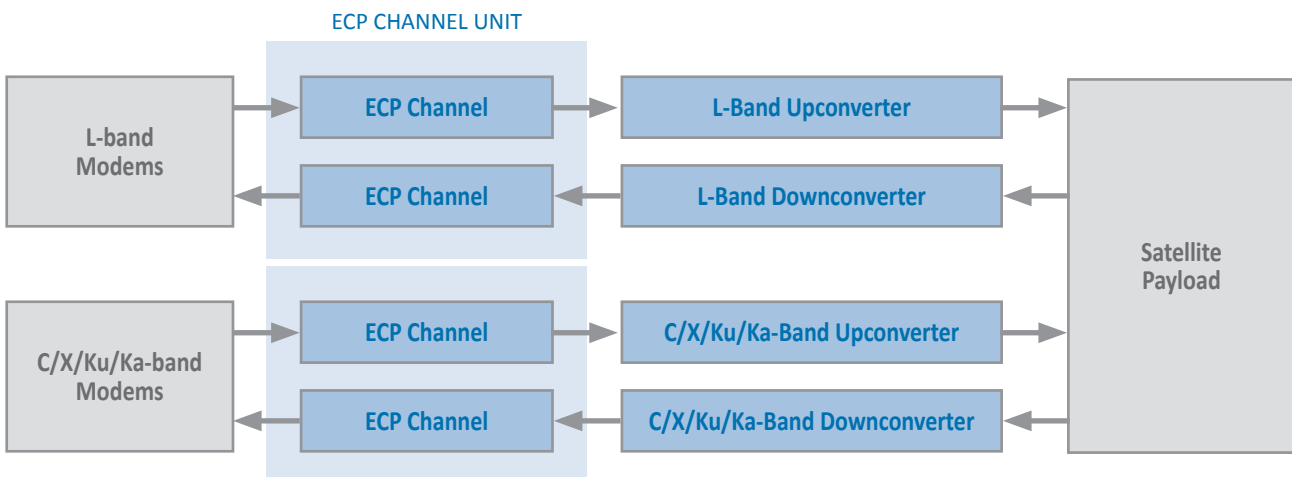

Propagation Channel Emulator

ECP-70

8 CNES PROPALOG SOFTWARE (OPTION)

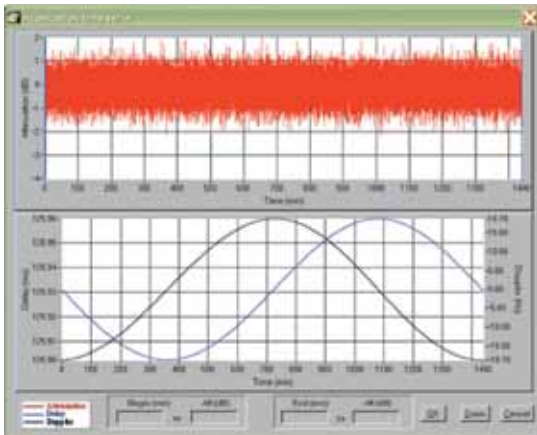

Data plot

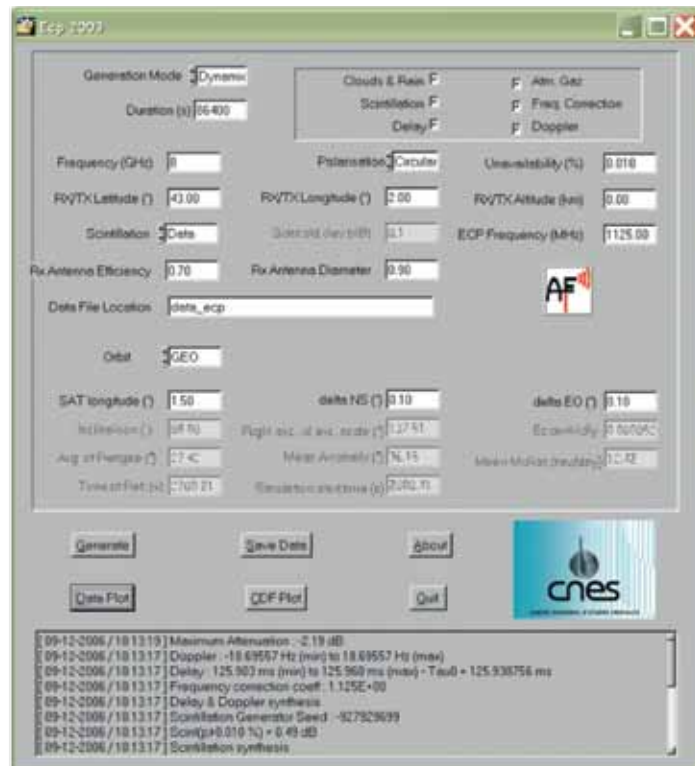

The Ecp 2007 configuration window includes the following parameters:

- Generation Mode: Dynamic
- Duration (s): 106400
- Frequency (GHz): 0
- FO/TK Latitude (°): 43.00
- Scintillation: Data
- Rx Antenna Efficiency: 0.70
- Data File Location: data_evp
- Orbit: GEO
- SAT longitude (°): 1.50
- Inclination (°): 08.70
- Alt of Payload (°): 27.4
- Time of Fix (s): 710.21
- Clouds & Rain: F
- Scintillation: F
- Delay: F
- Atm. Gas: F
- Freq. Correction: F
- Doppler: F
- Polarization: Circular
- Unavailability (%): 0.010
- FO/TK Longitude (°): 2.00
- FO/TK Altitude (km): 0.00
- Scintillation (var/Hz): 3.1
- ECP Frequency (MHz): 1125.00
- Rx Antenna Diameter: 0.90
- delta NS (°): 0.10
- delta EO (°): 0.10
- Flight alt. at av. state (°): 12.751
- Eccentricity: 0.00709
- Near Anomaly (°): 76.15
- Mean Motion (rev/day): 1.142
- Simulation duration (s): 210.71

Buttons: Generate, Save Data, About, Data Plot, CDF Plot, Quit.

Jammers window

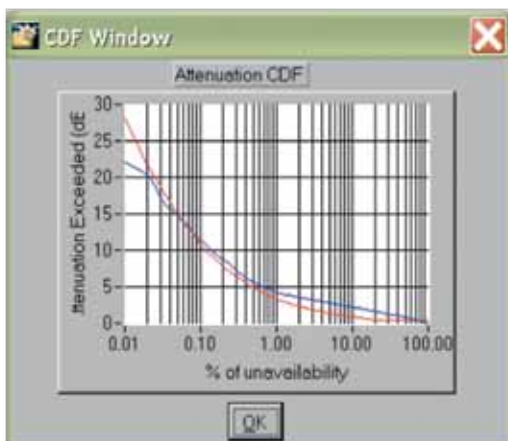

Cumulative density function

9 PROPAGATION DISTURBANCE MODELS

TWO DISTURBANCE SOFTWARE MODELS CAN BE PROVIDED WITH ECP:

- **STATIC MODE:** a fixed fading is applied to the signal. It is computed as a worst case according to the simulated link parameters. The fading (atmospherical gases, rain, clouds and flickering) models are those recommended by the International Telecommunication Union (ITU-R P.6, P.818-7, P.676-5, P.836-3, P.837-3, P.838-1, P.839-3, P.840-3 and P.453-8).
- **DYNAMICAL MODEL:** fading is time-varying. The rain, clouds and flickering events are computed according to a statistical model developed by CNES. (This model was successfully checked using ITU recommendations.)

IN BOTH CASES, THE TRANSMISSION DELAY AND THE DOPPLER FREQUENCY SHIFT FILES SIMULATE THE TRAJECTORY OF EITHER GEO OR LEO SATELLITES.



Propagation Channel Emulator

ECP-70

10 MULTI-PATH SIMULATOR (OPTION)

THE FOLLOWING PROCESSING IS ADDED AT THE END OF THE SIGNAL PROCESSING CHAIN OF THE STANDARD ECP:

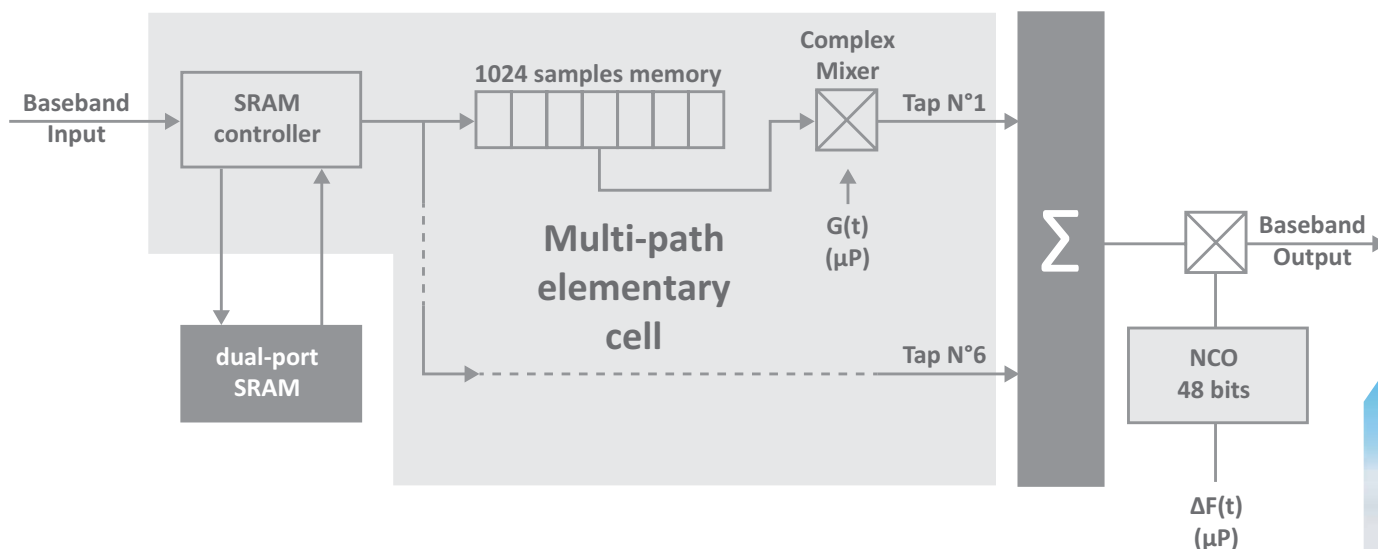

- ENABLES EITHER RICE OR RAYLEIGH CHANNEL SIMULATION THROUGH ADVANCED STATISTICAL JAKE'S LIKE MODEL.
- UP TO 24 SIMULTANEOUS "TAPS" (ECHOES AGGREGATION) DIVIDED INTO 4 SUBSETS ENABLING THE SIMULATION OF COMPLEX CONFIGURATIONS SUCH AS 4 SATELLITES CONSTELLATION OR 1 SATELLITE AND 3 EARTH REPEATERS FOR EXAMPLE.
- EACH ECHO STATISTICAL PARAMETERS, DELAY AND RELATIVE FREQUENCY SHIFT CAN BE UPDATED AT A 100 HZ RATE.
- EACH TAP MEAN DELAY IS SELECTABLE FROM 0 TO 15 MS.

APPLICATION:

TELEMETRY RECEIVER PERFORMANCE
TEST BENCH IN MULTIPATH
ENVIRONMENT.



www.elta.fr

Propagation Channel Emulator

ECP-70

11 TRACKING ERROR SIMULATOR (OPTION)

THE FOLLOWING PROCESSING IS ADDED AT THE END OF THE SIGNAL PROCESSING CHAIN OF THE STANDARD

The tracking error simulator performs sum and error channel generation in order to simulate the tracking signals provided by antenna sources.

The tracking simulator can work in 2 modes: 2-channels (ρ , θ) mode and 3-channels (Σ , ΔX , ΔY) mode.

Amplitude ratio between Σ and Δ channels can be set from 10 to 60 dB by 0.1 dB step.

Relative phase between Σ and Δ channels can be set from -180 to 179 deg. by 1 deg step.

These parameters can be updated at a 100 Hz rate.

Output channels (ρ , θ) configuration

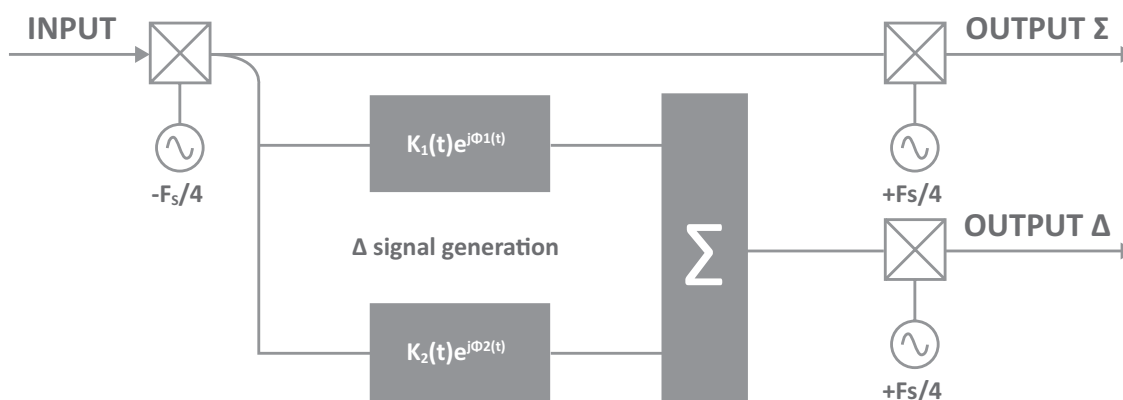

Output channels (Σ , ΔX , ΔY) configuration

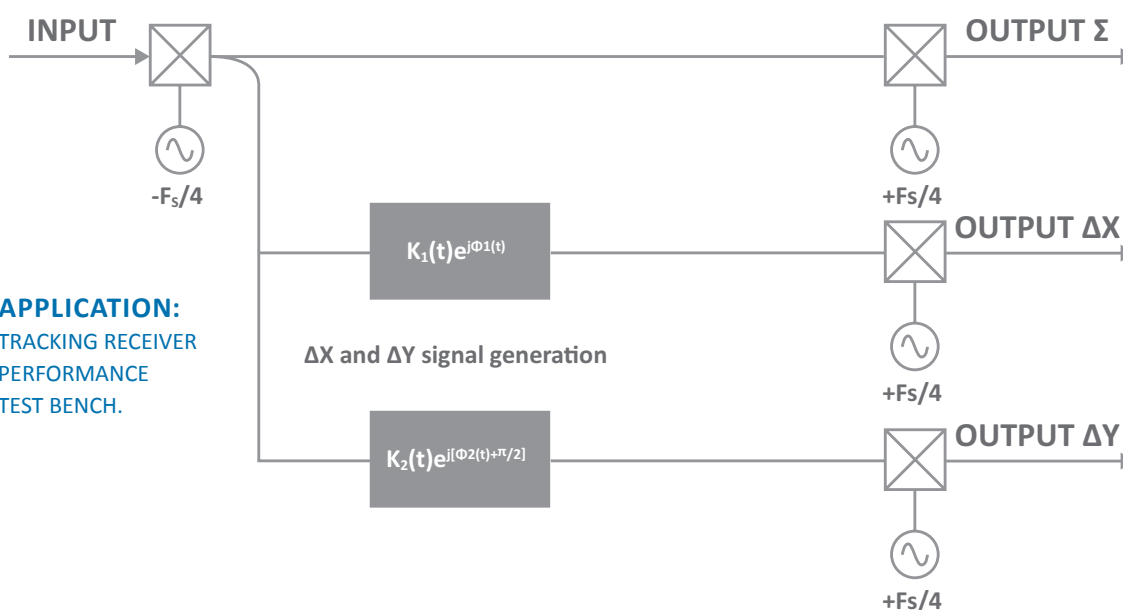

APPLICATION:
TRACKING RECEIVER
PERFORMANCE
TEST BENCH.

www.elta.fr

Propagation Channel Emulator

ECP-70

12 PHASE NOISE GENERATOR (OPTION)

THE DIGITAL PHASE NOISE GENERATOR IMPLEMENTS A FULL CUSTOMIZABLE PHASE NOISE CURVE COMPOSED OF 3 AREAS:

1. At carrier bottom, f^2 or f^3 shaped,
2. Nearly flat transition region (+5 dB/decade to -10 dB/decade) corresponding to the LO loop bandwidth,
3. VCO-like curve, f^2 shaped.

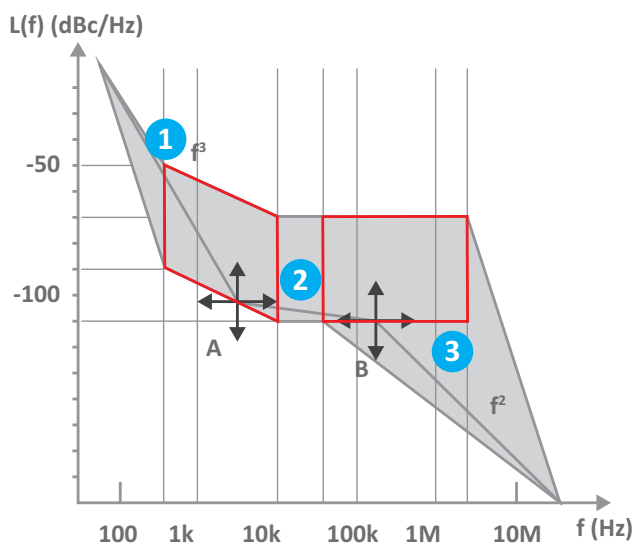

THE A AND B POINT COORDINATES ARE FULLY PROGRAMMABLE IN THE FOLLOWING DOMAINS:

POINT	FREQUENCY	AMPLITUDE
A	from 500 Hz to 10 kHz	-30 to -90 dBc/Hz -70 to -110 dBc/Hz
B	from 50 kHz to 2 MHz	-70 to -110 dBc/Hz

APPLICATION:
TELEMETRY RECEIVER
PERFORMANCE TEST BENCH
IN SPECIFIED PHASE NOISE ENVIRONMENT.

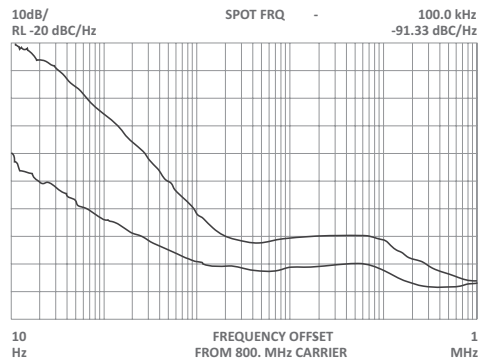

Real-world synthesized phase noise with ECP



www.elta.fr

Propagation Channel Emulator

ECP-70

13 AMPLIFIER NON LINEARITIES (OPTION)

The aim of the amplifier non linearities function is to simulate the gain and phase characteristics of an amplifier. Via a configuration file, the user specifies for the amplifier, a power curve and a phase curve versus the input power signal, $OBO = f(ISO)$. These curves describe the static behavior of an amplifier. When the ISO (Input Back off) is equal to 0 the OBO is equal to 0 too, and the OBO is at the maximum.

THE FILE CONTAINING AM/AM AND AM/PM AMPLIFIER CHARACTERISTICS WILL BE AN ASCII FILE, WITH THE «.LSF» EXTENSION.

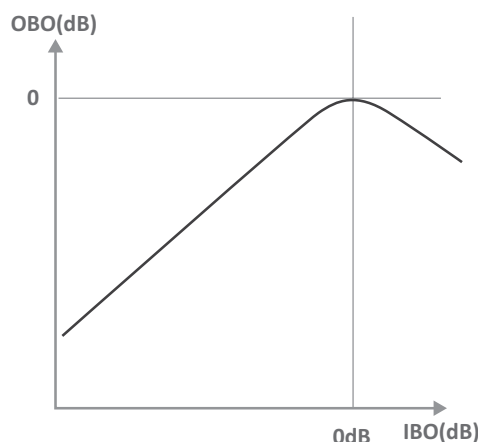

14 FILTER (OPTION)

The aim of this function is to emulate analog filters like OMUX and IMUX of satellite payload. The coefficients file can be generated using the filter synthesis software or by manual editing. The file containing coefficients will be an ASCII file. The coefficients are given as follows:

TAGS	DESCRIPTION	VALUES
FRInn±xxxxxx	Real part of the FIR Filter	nn: coefficient nt number from 1 to 20 -032768≤±xxxxxx≤032767
FRQnn±xxxxxx	Imaginary part of the FIR Filter	nn: coefficient nt number from 1 to 20 -032768≤±xxxxxx≤032767
INInn±xxxxxx	Real part of the IIR Numerator Filter	nn: coefficient nt number from 1 to 20 -032768≤±xxxxxx≤032767
INQnn±xxxxxx	Imaginary part of the IIR Numerator Filter	nn: coefficient nt number from 1 to 20 -032768≤±xxxxxx≤032767
IDInn±xxxxxx	Real part of the IIR Denominator Filter	nn: coefficient nt number from 1 to 20 -032768≤±xxxxxx≤032767
IDQnn±xxxxxx	Imaginary part of the IIR Denominator Filter	nn: coefficient nt number from 1 to 20 -032768≤±xxxxxx≤032767
GFMnxxxxx	Mantissa of the Gain	n: mantissa of the n^{on} gain from 1 to 4 0≤xxxxx≤32767
GFE n_{xx}	Exponent of the Gain	n: exponent of the n^{on} gain from 1 to 4 0≤xx≤31

THE FILTER DISPLAYED IS COMPUTED USING THE COEFFICIENTS FILE SELECTED.



www.elta.fr

Propagation Channel Emulator

ECP-70

15 SPECIFICATIONS

BASIC SIMULATOR

Level fading	+5 to -40 dB (0.1 dB step)
Propagation Delay	0 to 500 ms (1 ns step), continuously variable
Delay slope	up to $\pm 50\,000$ m/s (0.001 m/s step), phase continuity guaranteed
Frequency dopler shift	up to ± 2 MHz (1 MHz step)
AGC mode	Automatic / Manual, Input AGC attenuator range (30 dB)

IF SIGNALS

Input/Output Center Frequency	70 MHz	
Input Level	-10 to -40 dBm	
Output Level	-5 to -80 dBm	
VSWR	≤ 1.3	
Bandwidth	40 MHz @ 1 dB	
Amplitude Flatness	± 0.5 dB	
Group Delay Variation	≤ 40 ns pp over 40 MHz	
Spectral Purity	55 dBc minimum, 60 dBc typ.	
Resolution	12 bits DAC & ADC	
Phase Noise	10 Hz	-75 dBc/Hz
	100 Hz	-100 dBc/Hz
	1 kHz	-110 dBc/Hz
	10 kHz	-110 dBc/Hz
	100 kHz	-115 dBc/Hz
≥ 1 MHz	-130 dBc/Hz	

AWGN GENERATOR

Generator type	Chaotic Uniform Generator with Gaussian Transform
Bandwidth	40 MHz flat
S/N Control	Single Measurement at Start or Continuous
S Measurement	FFT Over Specified Bandwidth
S/N Selection	+60 to -60 dB (0.01 dB step)
S Bandwidth	0 to 40 MHz

SPECTRUM ANALYZER

Spectrum Shot	1024 pts over 40 MHz (40 kHz resolution)
Windowing	Flat Top, Hanning, Rectangular
Spectrum Averaging Factor	2, 4, 8, 16, 32, 64



Propagation Channel Emulator

ECP-70

REMOTE CONTROL

Interface	Ethernet
Protocol	TCP/IP
Real-time Data Playback Rate	1, 0.1 or 0.01 s Selectable
Data Interpolation Rate	0.1 ms

ENVIRONMENTAL CONDITIONS

- **OPERATING:**
 - Temperature 10° C to 40° C
 - Humidity Up to 95 % at 30° C
- **NON OPERATING:**
 - Temperature -40° C to 70° C
 - Humidity Up to 95 % at 30° C
- **POWER SUPPLY:**
 - Voltage 230 V ±10 % / 47 to 63 Hz
 - Power ≤ 180 VA
- **PHYSICAL CHARACTERISTICS:**
 - Drawer 19 inches
 - Depth 460 mm
 - Height 4U
 - Weight 22 Kgs

ORDERING INFORMATION

- **MODELS:**
 - 1 channel ECP-70, 14N62683/A
 - 2 channels ECP-70, 14N62684/A
 - 3 channels ECP-70, 14N63406/A
- **OPTIONS (per channel):**
 - ECP – 001 Thermal noise generator
 - ECP – 002 Phase noise generator
 - ECP – 003 Multi-path Rayleigh/Rician channel simulation
 - ECP – 004 Jammers generation
 - ECP – 005 Amplifier non linearities
 - ECP – 006 Output analog filter (IMUX / OMUX Filters)
 - ECP – 007 Tracking error simulator
 - ECP – 008 CNES PROPALOG software
 - ECP – 009 ECP supervision remote software
- **NOTA:**
 1. Option 003 is needed for option 006
 2. Options 003 & 006 can't be integrated in an ECP-70 3 channels 14N63406/A
 3. Option 005: when this option is chosen, it's set up on all channels

